

High Head Pump

HH125

Overview:

The 6" suction x 4" discharge self-priming centrifugal HH125c high head pump provides up to a maximum of 900 gallons per minute pumping and up to 370 feet of head. This pump is usually mounted on a trailer and features the standard PowerPrime Clean Prime Venturi priming system which allows it to run continuously, unattended and even run dry.

Features:

- Suction lift to 28 feet
- Continuous self-priming
- Runs dry unattended
- 12-volt auto start electric control panel
- Pedestal-mounted
- Flex coupled to diesel engine
- 24-hour capacity fuel tank
- Compressor fitted to operate air-injector priming system
- 316 Stainless steel or chromium steel open impellers
- Replaceable wear rings

Specs:

Maximum Flow	900 GPM
Maximum Head	370 feet
Pump Size	6" x 4"
Maximum Solids Handling	1.25 inch
Dry weight	4,280 lbs.
Footprint: Trailer mounted model	135" x 62"
Fuel tank	120 gallon
Fuel consumption	5.4 gph @ 2,200 RPM



Accessories:

- Spillguard
- Suction and Discharge Hoses
- Fuel Nurse Tank
- VFD for electric driven models

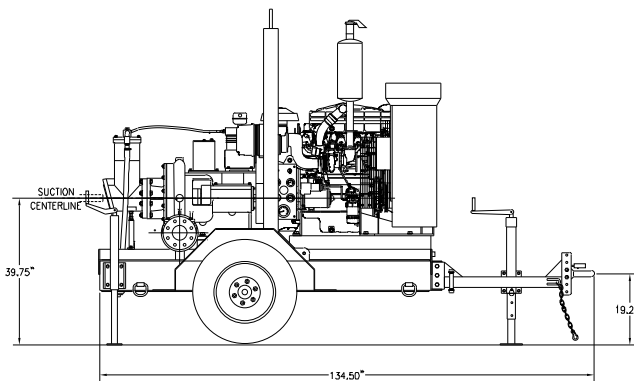
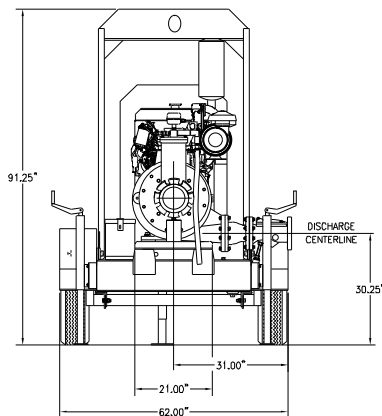

PUMPS • TANKS • FILTRATION • PIPE • SPILLGUARDS

Rain for Rent is a registered trademark of Western Oilfields Supply Company. Features and specifications are subject to change without notice.

Liquid Ingenuity
800-742-7246
rainforrent.com



Rain For Rent

CURVE: 01-0133-02-11
PUMP: HH-125

SUCTION 6"

DISCHARGE 4"

MAX. SPHERE 1.14"

IMPELLER 3 VANES

IMPELLER 14.57"

IMPELLER & WEAR RINGS 316 S/S

ALL INFORMATION CONTAINED IN OR DISCLOSED BY THIS DOCUMENT IS CONSIDERED CONFIDENTIAL AND PROPRIETARY BY RAIN FOR RENT. ALL DISCLOSURES OF DESIGN INFORMATION AND REPRODUCTION OF THIS DOCUMENT AND ALL SALES RIGHTS ARE EXCLUSIVELY RESERVED BY AND TO RAIN FOR RENT AND COMMUNICATION OF THIS INFORMATION TO OTHERS IS PROHIBITED WITHOUT THE PRIOR WRITTEN CONSENT OF RAIN FOR RENT.

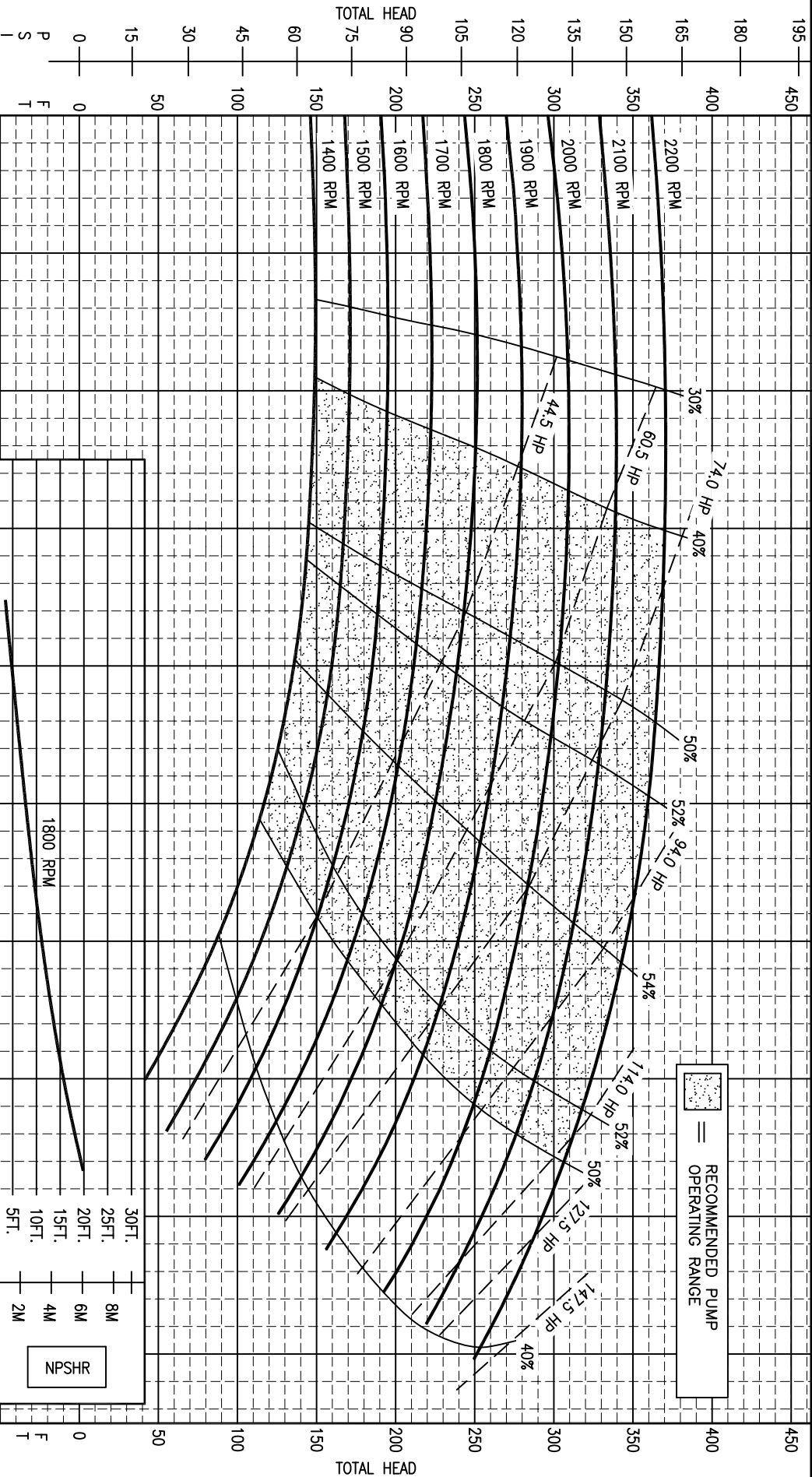

FLOW - CLEAR WATER PERFORMANCE (US GPM)

CONFIDENTIAL

-PUMP PERFORMANCE CURVES DO NOT INCLUDE CHECK VALVE LOSSES
-POWER CURVES INCLUDES AIR COMPRESSOR POWER CONSUMPTION