



## Model DV-200c

### Standard Features

- Hot Dip Galvanized Trailers and Skids
  - Radiator Enclosure
  - Battery Box
  - Wheels
- Zinc Plated Jacks
- Emissions Certified Engines
  - Perkins and John Deere
- DOT LED lights
- Electric Brakes with Safety breakaway
- Locking Battery Box

### Pump Features

- Solids-handling capabilities to 3.375" diameter maximum
- Continuous self-priming
- Runs dry unattended
- Suction lift up to 28 ft.
- Skid- or trailer-mounted
- Auto-start-capable control panel



### Technical

- SAE-mounted
- 12 volt, electric start with control panel
- Skid- or trailer-mounted with optional lifting bale
- 24-hour minimum capacity fuel tank
- Compressor/Venturi automatic priming system
- Electric drive option available
- Sound attenuated option available

### Material Specifications

- Standard Build – ASTM A48 CLASS 30 Gray Iron volute Enclosed 2 vane non-clog impeller and replaceable wear rings
- Pump Shaft LaSalle 1144 stress proof steel
- Mechanical Seal Tungsten carbide vs. silicon carbide mating faces Oil-bath lubrication for dry running
- Suction / discharge flanges ANSI 150# FF

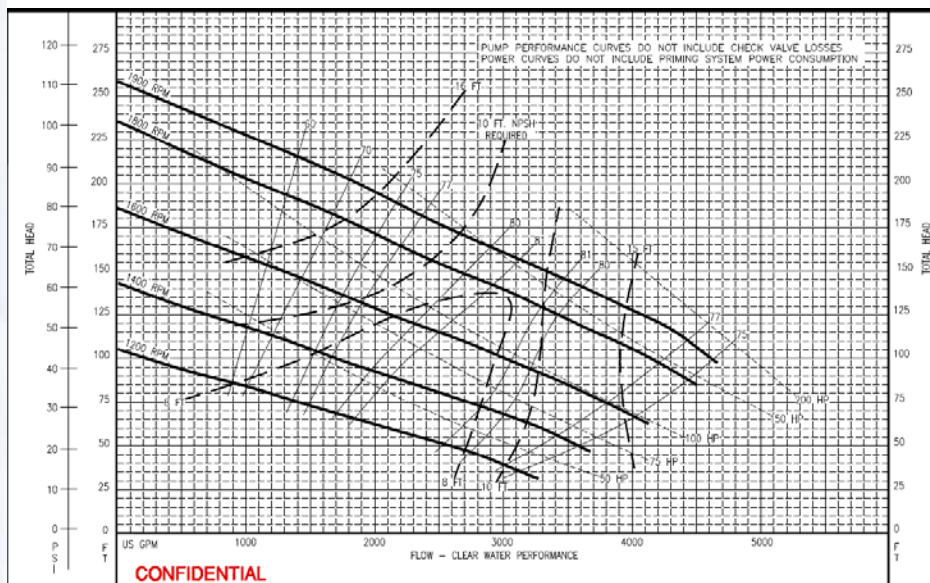

**Rain for Rent**  
 P.O. Box 2248  
 Bakersfield CA 93303  
 800-742-7246  
 661-393-1542  
 FAX 661-393-1542  
 www.rainforrent.com  
 info@rainforrent.com

Rain for Rent is a registered trademark of Western Oilfields Supply Company. Features and Specifications are subject to change without notice.



## DV-200c Technical Specifications

### Production Curve

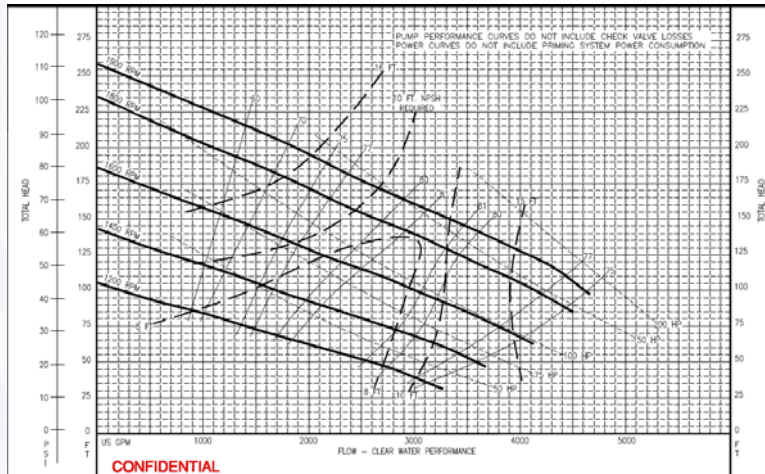

### Performance Specs

#### 2 VANE NON-CLOG IMPELLER

Minimum Operating Speed:	1400 RPM
Maximum Operating Speed:	1900 RPM
Maximum Head:	260 FT
Maximum Flow:	4600 GPM
Fuel Consumption:	Perkins 1106D-E60TA
	(4000 GPM @ 125' TDH) 8.5 GPH @ 1900 RPM

### Design Details

<b>Pump Designation:</b>	DV-200C
<b>Pump Description:</b>	Centrifugal end suction pump, single stage, volute type, 2 vane non-clog impeller
<b>Solid Handling Size:</b>	Up to 3.375 inches (45mm)
<b>Operating Temperature</b>	MIN: -4°F (-20°C) - MAX: +212°F (+100°C)

### Dimensions

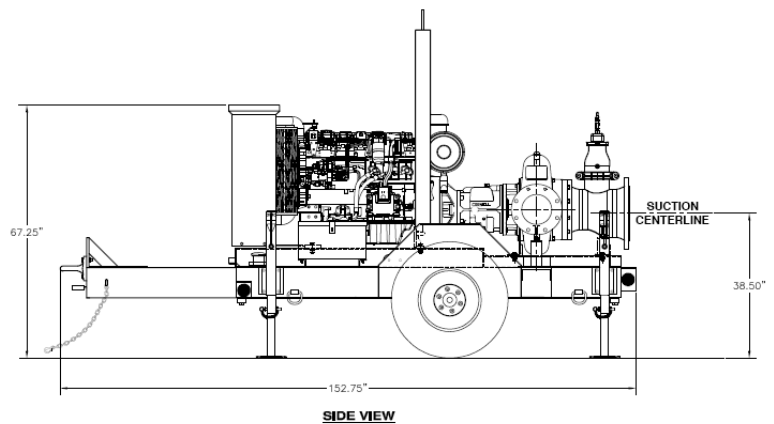
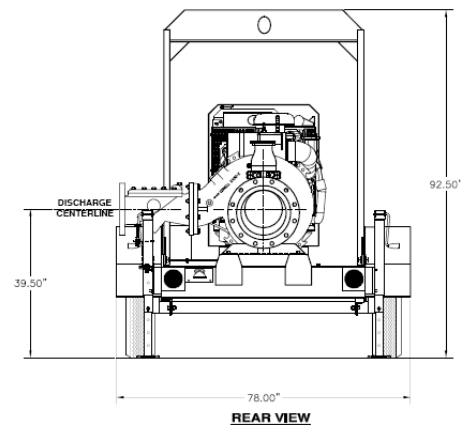

**Rain for Rent**  
 P.O. Box 2248  
 Bakersfield CA 93303  
 800-742-7246  
 661-399-9124  
 FAX 661-393-1542  
 www.rainforrent.com  
 info@rainforrent.com

Rain for Rent is a registered trademark of Western Oilfields Supply Company. Features and Specifications are subject to change without notice.