



## Model DV-200

**Size 8" X 8"**

### Standard Features

- Hot Dip Galvanized Trailers and Skids
  - Radiator Enclosure
  - Battery Box
  - Wheels
- Zinc Plated Jacks
- Emissions Certified Engines
  - Perkins and John Deere
- DOT LED lights (optional)
- Electric Brakes with Safety breakaway
- Locking Battery Box

### Pump Features

- Solids handling capabilities to 3" diameter maximum
- Continuous self priming
- Runs dry unattended
- Suction lift to 28'
- Skid or trailer mounted
- Stainless Steel and CD4MCu\* Pump Options



### Technical

- The DV-200 is direct coupled to a John Deere 4045T-150 diesel fueled engine.
- The pump and engine are skid or trailer mounted with lifting bracket and integral 24-hour minimum capacity fuel tank.
- The engine is 12 volt, electric start.
- The compressor is fitted to operate the air-ejector priming system.
- Other makes of diesel engines and electric power options are available.

### Material Specifications

- Standard build is 316 stainless steel open impellers and replaceable wear plates.
- Pump shaft is 431 stainless steel. All other major pump components are spheroidal graphite iron.
- The mechanical seal, with solid silicon carbide mating faces, is lubricated in an oil bath.
- Suction and discharge flanges are 8" ANSI 150# FF.

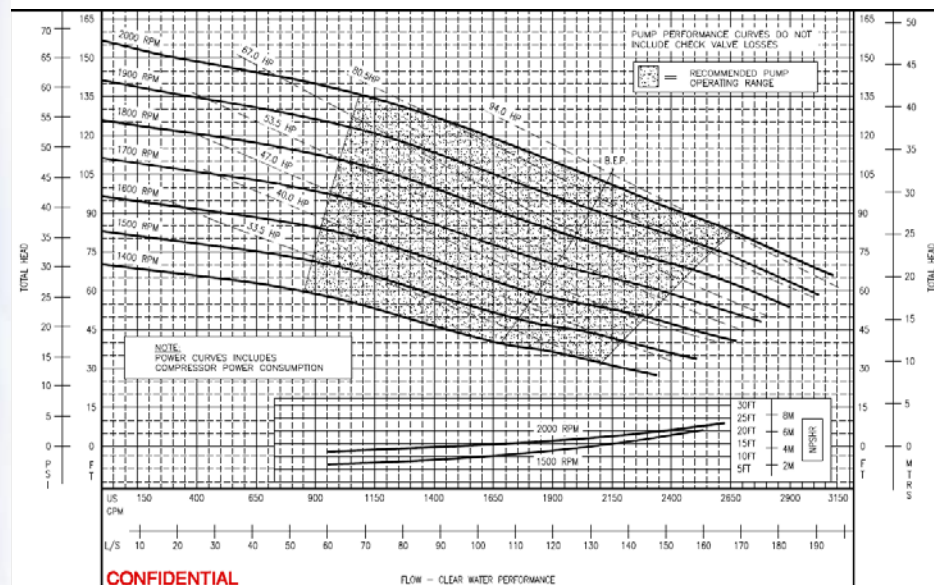

**Rain for Rent**  
 P.O. Box 2248  
 Bakersfield CA 93303  
 800-742-7246  
 661-393-1542  
 FAX 661-393-1542  
 www.rainforrent.com  
 info@rainforrent.com

Rain for Rent is a registered trademark of Western Oilfields Supply Company. Features and Specifications are subject to change without notice.



## DV-200 Technical Specifications

### Production Curve

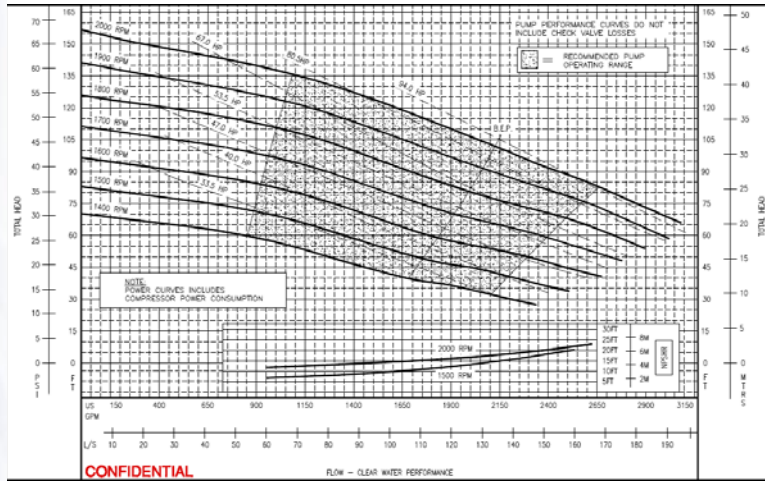

### Performance Specs

Maximum Head:	152 ft.
Maximum Flow:	3100 gpm

### Design Details

<b>Pump Designation:</b>	DV-200
<b>Pump Description:</b>	Centrifugal end suction pump, single stage, volute type, 2 vane non-clog impeller
<b>Solid Handling Size:</b>	Up to 3 inches (76.2mm)
<b>Operating Temperature</b>	MIN: -4°F (-20°C) - MAX: +212°F (+100°C)

### Dimensions

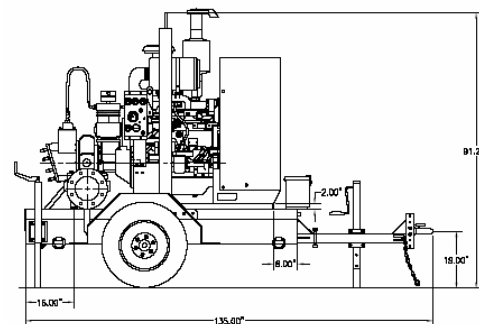
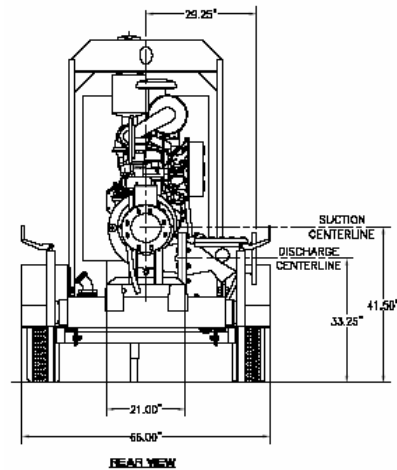

**Rain for Rent**  
 P.O. Box 2248  
 Bakersfield CA 93303  
 800-742-7246  
 661-399-9124  
 FAX 661-393-1542  
 www.rainforrent.com  
 info@rainforrent.com

Rain for Rent is a registered trademark of Western Oilfields Supply Company. Features and Specifications are subject to change without notice.