

| REV.NO. | DESCRIPTION | PREVIOUS DWG | BY | DATE |
|---------|-------------|--------------|----|------|
| △ | | | | |

| ITEM | QTY. | REF. | DESCRIPTION |
|------|------|------|-------------|
| | | | |

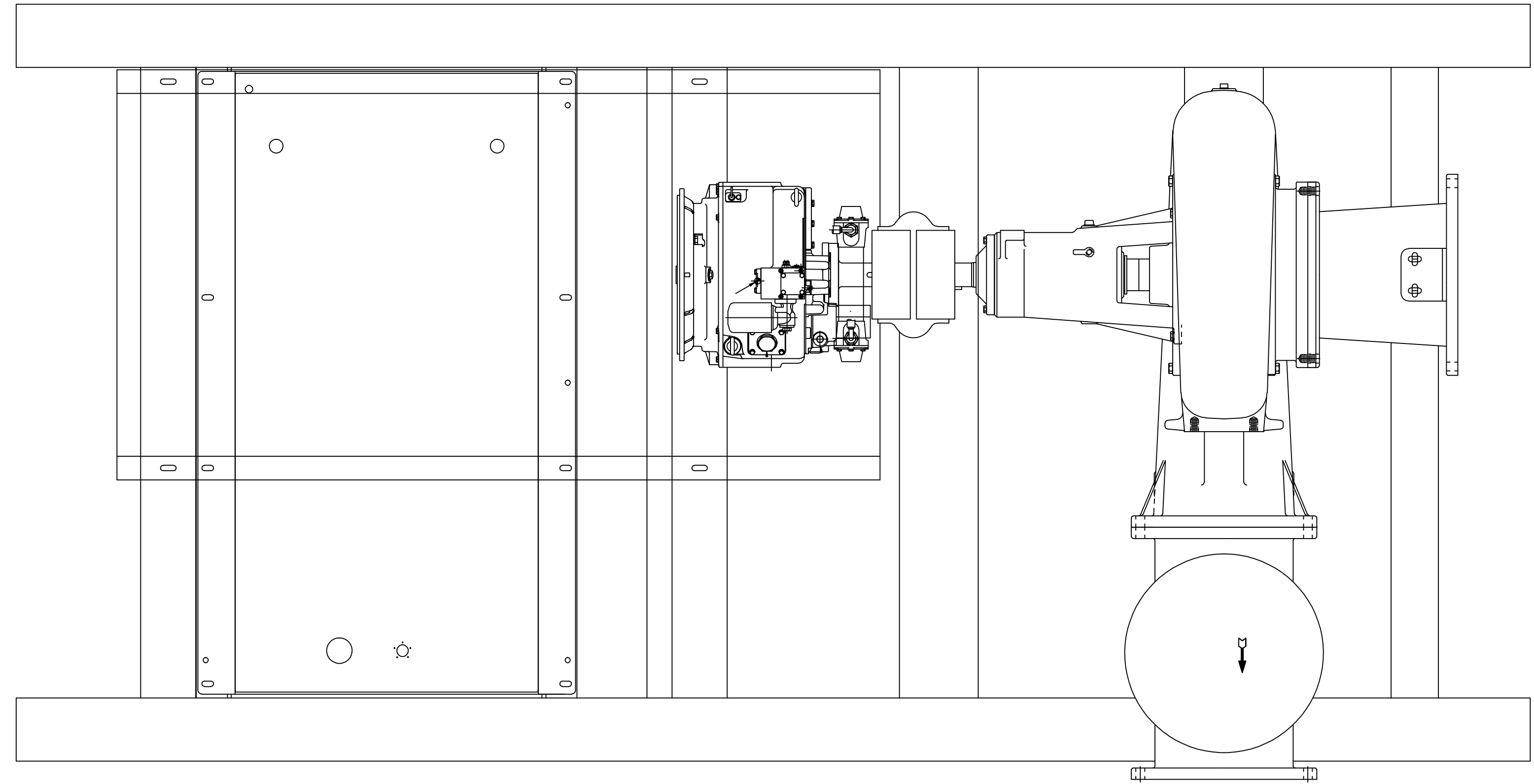

SUCTION = 18" - 150LB. FLANGE
DISCHARGE = 16" - 150LB. FLANGE
SHIPPING WEIGHT = 15,000LBS. (EMPTY FUEL TANK WEIGHT)
FUEL TANK CAPACITY = 100 GALLONS

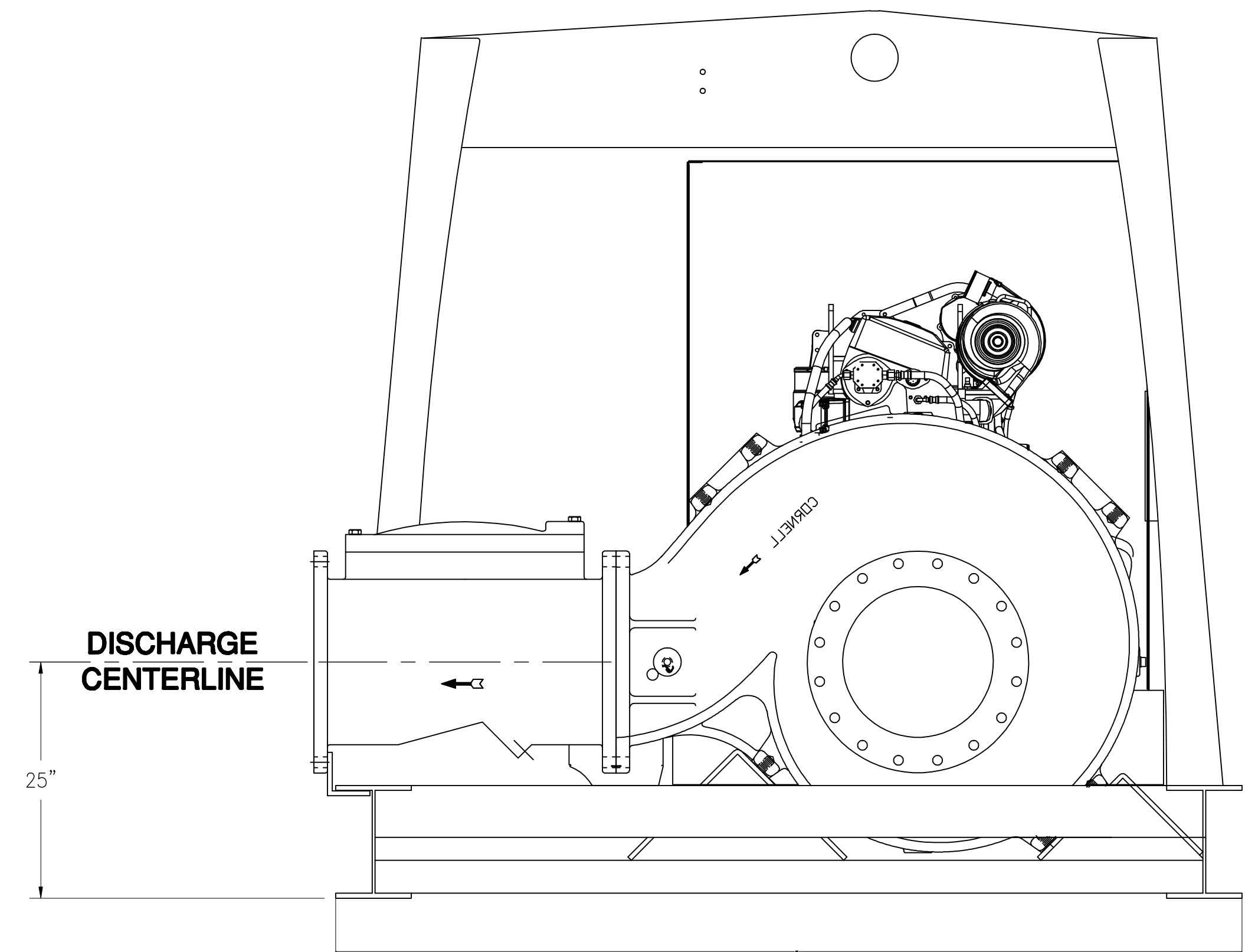
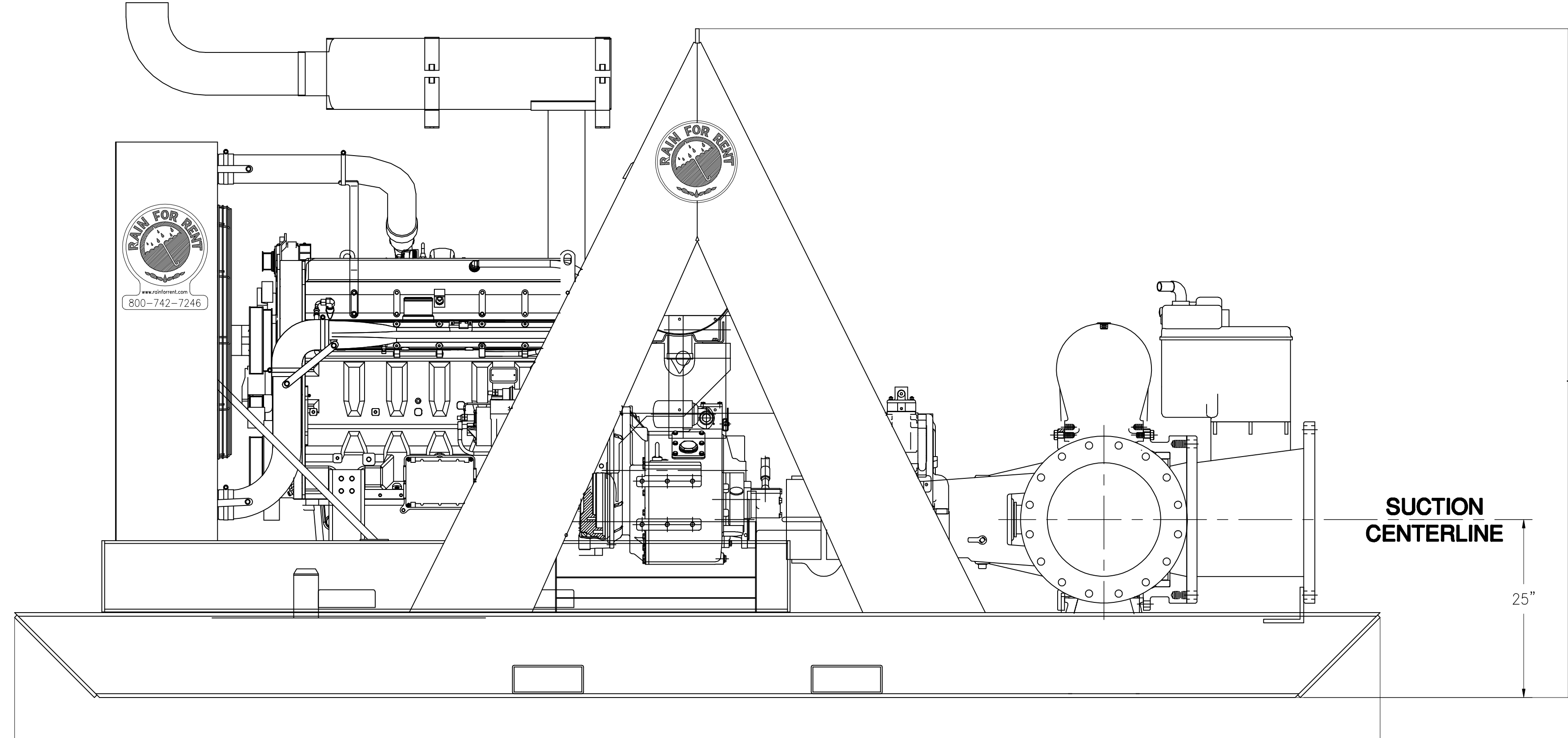

CONFIDENTIAL

PLAN VIEW

| | |
|-----------|--------------|
| DATE: | 01-08-2002 |
| SCALE: | NOT TO SCALE |
| DESIGNED: | RFR |
| CHECKED: | RFR |
| DRAWN: | M. STEVENSON |

DV-400C

RAIN FOR RENT

Rain For Rent Engineering
3404 STATE ROAD, P.O. BOX 2248 BAKERSFIELD, CA 93303

01-0594-02-01