

REV.NO.	DESCRIPTION	PREVIOUS DWG	BY	DATE

ITEM	QTY.	REF.	DESCRIPTION

SUCTION = 8" - 150LB. FLANGE
DISCHARGE = 8" - 150LB. FLANGE
SHIPPING WEIGHT = 5500LBS. (EMPTY FUEL TANK WEIGHT)
FUEL TANK CAPACITY - 95 GALLONS

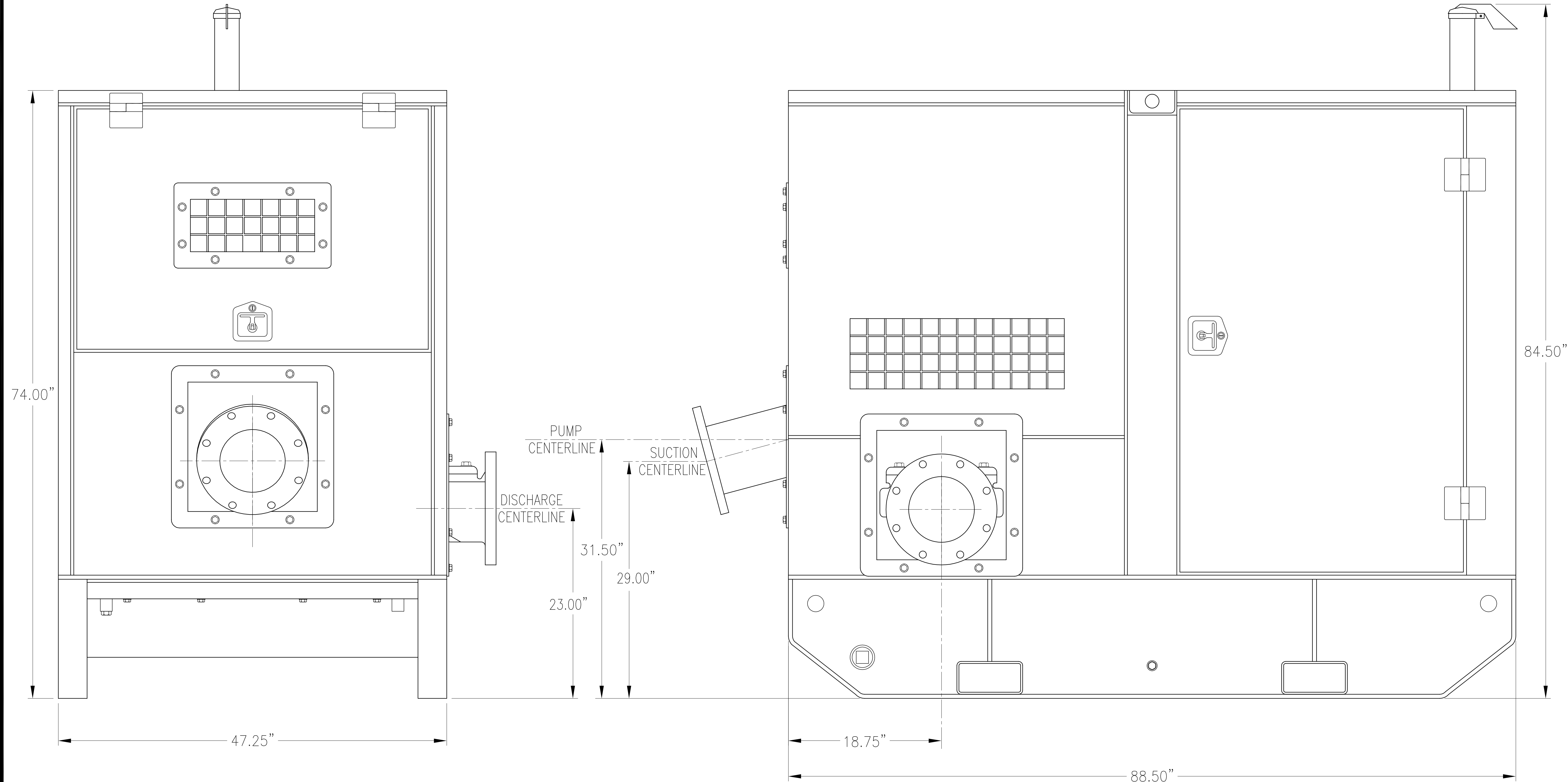

DATE:	05-22-2003
SCALE:	NOT TO SCALE
DESIGNED:	
CHECKED:	
DRAWN:	R. ROGERS
SHEET:	1 OF 1
DWG NO:	SA-DV-200

SA-DV-200

JOHN DEERE 4045T

Rain For Rent Engineering
3404 STATE ROAD, PO BOX 2248 BAKERSFIELD, CA 93303

ALL INFORMATION CONTAINED IN OR DISCLOSED BY THIS DOCUMENT IS UNCLASSIFIED EXCEPT WHERE SHOWN OTHERWISE. THIS DOCUMENT IS EXCLUSIVELY RESERVED BY AND TO RAIN FOR RENT. NO PART OF THIS DOCUMENT IS TO BE REPRODUCED OR TRANSMITTED IN ANY FORM OR BY ANY MEANS, ELECTRONIC OR MECHANICAL, INCLUDING PHOTOCOPYING, RECORDING, OR BY ANY INFORMATION STORAGE AND RETRIEVAL SYSTEM, WITHOUT THE WRITTEN CONSENT OF RAIN FOR RENT.

1	SHEET OF	1
DRAWING NUMBER		
103609		
JOB NUMBER		
1030527		

REV.NO.	DESCRIPTION	PREVIOUS DWG	BY	DATE

ITEM	QTY.	REF.	DESCRIPTION

SUCTION = 8" - 150LB. FLANGE
DISCHARGE = 8" - 150LB. FLANGE
SHIPPING WEIGHT = 6100LBS. (EMPTY FUEL TANK WEIGHT)
FUEL TANK CAPACITY = 140 GALLONS

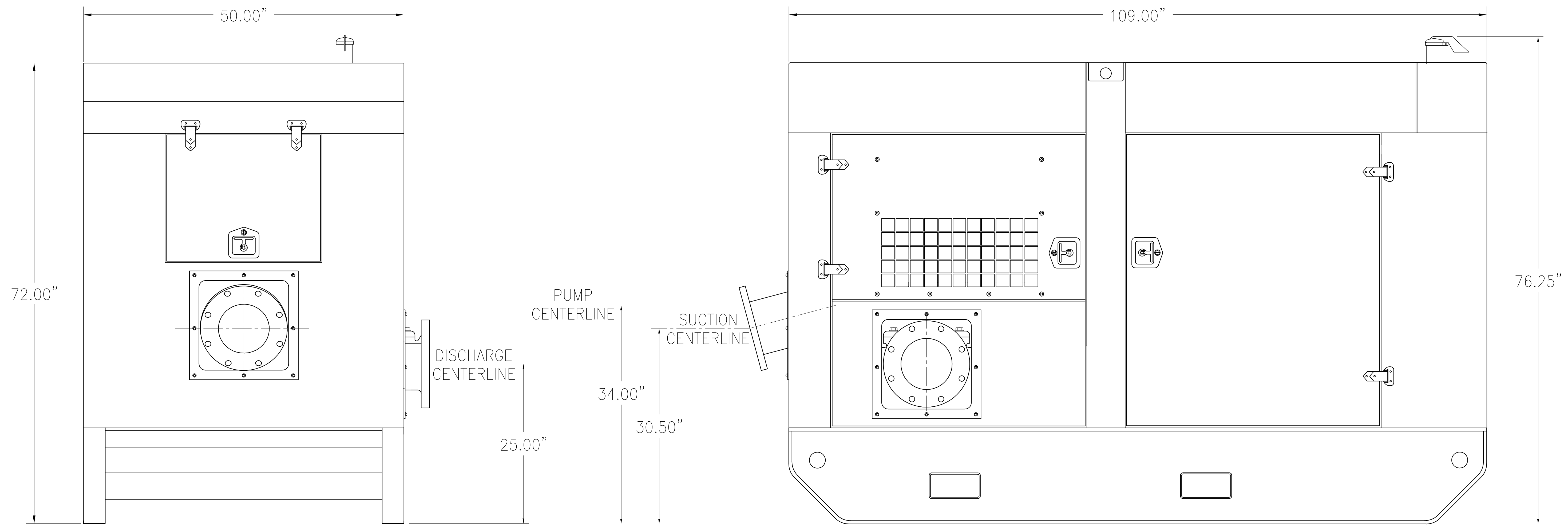

DATE:	05-22-2003
SCALE:	NOT TO SCALE
DESIGNED:	
CHECKED:	
DRAWN:	R. ROGERS
SHEET:	D

SA-DV-200

PERKINS 1004-40TW

Rain For Rent Engineering
3404 STATE ROAD, PO BOX 2248, BAKERSFIELD, CA 93303

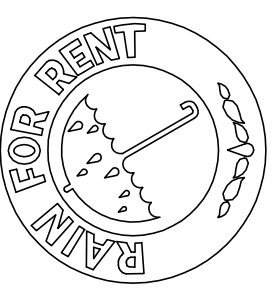

ALL INFORMATION CONTAINED IN OR DISCLOSED BY THIS DOCUMENT IS CONSIDERED CONFIDENTIAL AND NOT BE LOANED, REPRODUCED, COPIED, DISCLOSED OR USED IN ANY MANNER WITHOUT THE WRITTEN CONSENT OF RAIN FOR RENT.

1	SHEET OF	1
DRAWING NUMBER		
103610		
JOB NUMBER		
1030527		