

# Ag/Clear Water Pump

5RB

## Overview:

The 8" suction x 5" discharge centrifugal, submersible or turbine 5RB pump provides up to a maximum of 3,000 gallons per minute pumping and up to 370 feet of head. This high-performance, low-maintenance pump is usually mounted on a trailer for ease of use.

## Features:



## Specs:

Maximum Flow	3,000 GPM
Maximum Head	370 feet
Pump Size	8" x 5"
Maximum Solids Handling	1 inches
Dry weight	
Footprint	141" x 84"

## Accessories:

- Spillguard
- Suction and Discharge Hoses
- Fuel Nurse Tank
- VFD for electric driven models

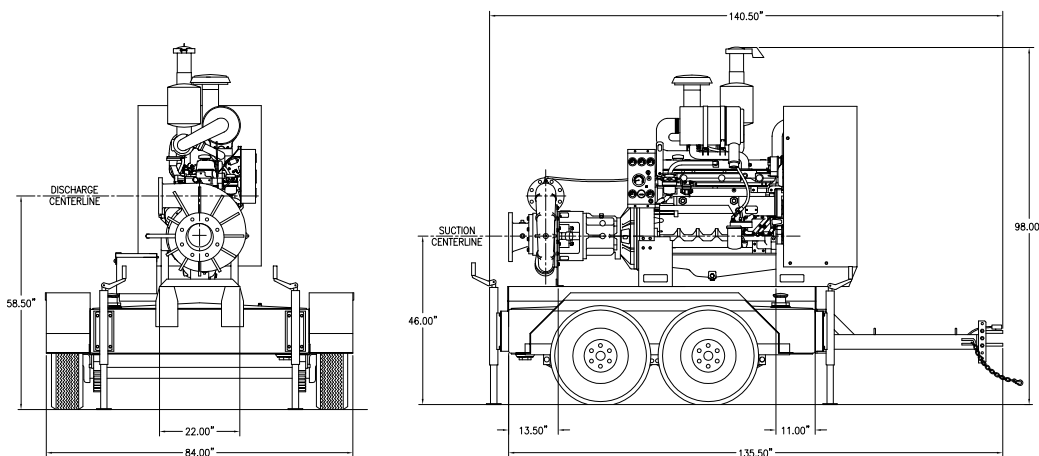

PUMPS • TANKS • FILTRATION • PIPE • SPILLGUARDS

Rain for Rent is a registered trademark of Western Oilfields Supply Company. Features and specifications are subject to change without notice.

Liquid ingenuity.™

800-742-7246  
rainforrent.com



# Rain For Rent

CURVE: 01-0133-02-50

PUMP : 5RB

SUCTION  
8"

DISCHARGE  
5"

MAX. SPHERE  
1"

IMPELLER  
6 VANE

IMPELLER  
13.5"

IMPELLER &  
WEAR RINGS  
BRASS

ALL INFORMATION CONTAINED IN OR DISCLOSED BY THIS DOCUMENT IS CONSIDERED CONFIDENTIAL AND PROPRIETARY BY RAIN FOR RENT. ALL DISCLOSURES OF DESIGN INFORMATION AND REPRODUCTION OF THIS DOCUMENT AND ALL SALES RIGHTS ARE EXCLUSIVELY RESERVED BY AND TO RAIN FOR RENT AND COMMUNICATION OF THIS INFORMATION TO OTHERS IS PROHIBITED WITHOUT THE PRIOR WRITTEN CONSENT OF RAIN FOR RENT

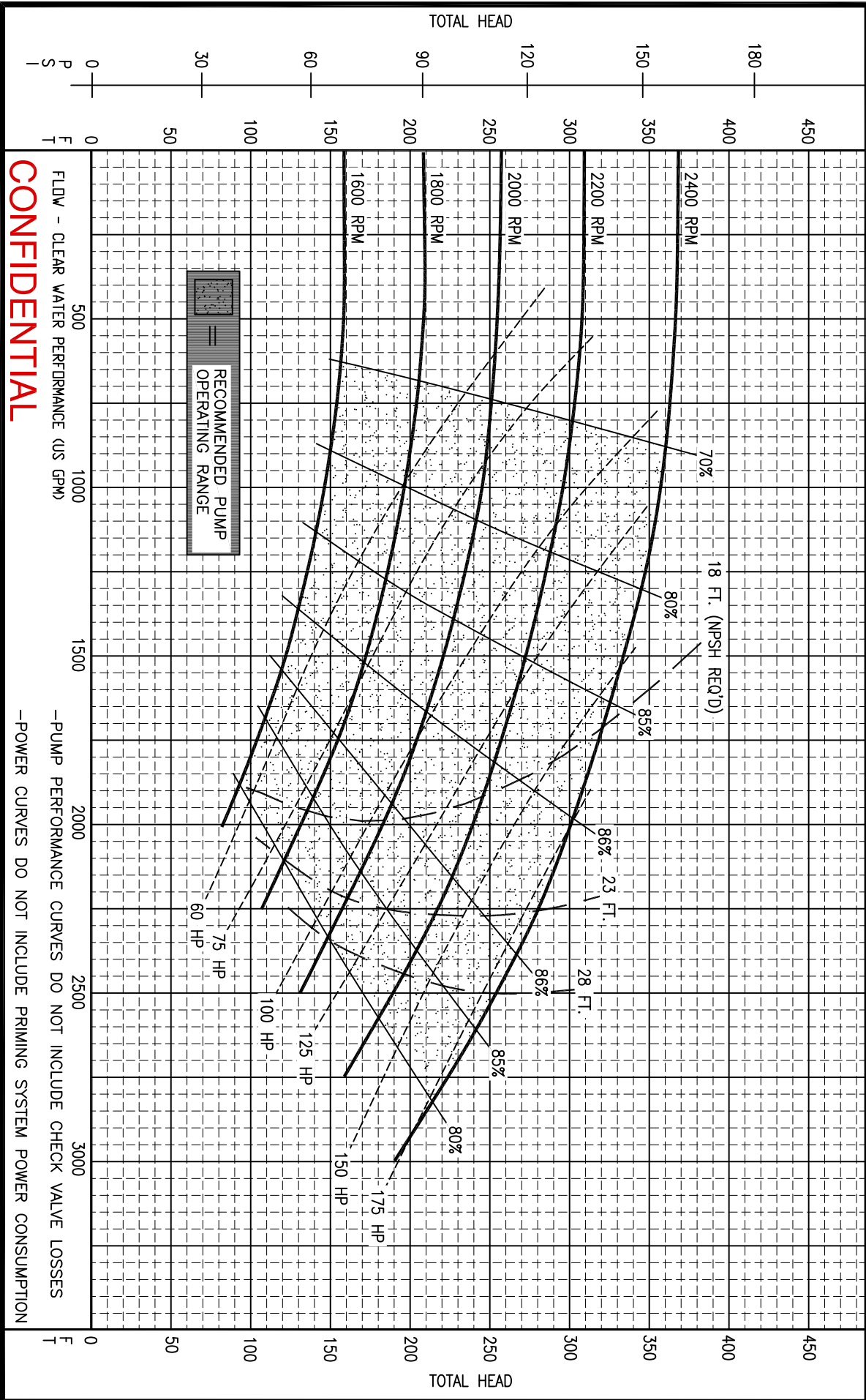

FLOW - CLEAR WATER PERFORMANCE (US GPM)

**CONFIDENTIAL**

-PUMP PERFORMANCE CURVES DO NOT INCLUDE CHECK VALVE LOSSES  
-POWER CURVES DO NOT INCLUDE PRIMING SYSTEM POWER CONSUMPTION