

Sewage and Trash Pump

DV150

Overview:

The 6" suction x 6" discharge self-priming centrifugal DV150 trash and sewage pump provides up to a maximum of 2,200 gallons per minute pumping and up to 157 feet of head. This pump is usually mounted on a trailer and features the standard PowerPrime Clean Prime Venturi priming system which allows it to run continuously, unattended and even run dry.

Features:

- Continuous self-priming
- Runs dry unattended
- 12 volt, electric start with auto-start capable control panel
- Flex coupled to diesel engine
- 24-hour minimum capacity fuel tank
- Compressor fitted to operate the air-ejector priming system
- Cast iron wet end with open impellers
- Replaceable wear plates
- SAE Mounted
- Suction lift up to 28ft.

Specs:

Maximum Flow	2,200 GPM
Maximum Head	157 feet
Pump Size	6" x 6"
Maximum Solids Handling	3 inches
Dry weight	3,800 lbs.
Footprint: Trailer mounted model	135.25" x 66"
Fuel tank	120 gallon
Fuel consumption	4.2 gph @ 2,200 RPM



The DV150 is also available sound attenuated.

Accessories:

- Spillguard
- Suction and Discharge Hoses
- Fuel Nurse Tank
- VFD for electric driven models

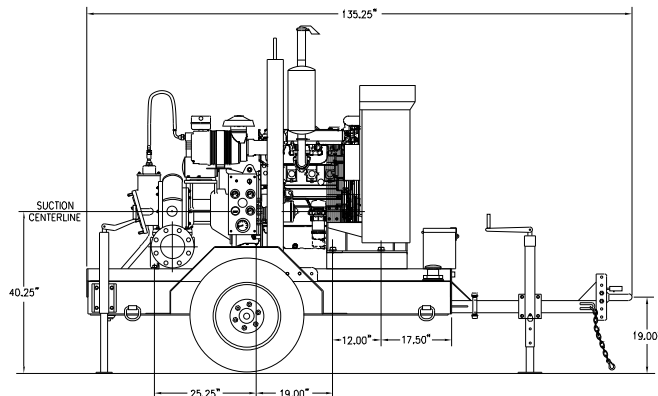
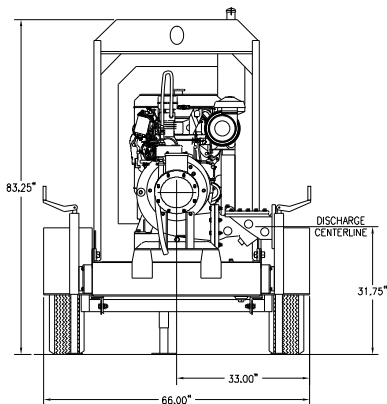

PUMPS • TANKS • FILTRATION • PIPE • SPILLGUARDS

Rain for Rent is a registered trademark of Western Oilfields Supply Company. Features and specifications are subject to change without notice.

Liquid Ingenuity®
800-742-7246
rainforrent.com



Rain For Rent

CURVE: 01-0133-02-06

PUMP : DV-150

IMPELLER & WEAR RINGS
316 S/S

ALL INFORMATION CONTAINED IN OR DISCLOSED BY THIS DOCUMENT IS CONSIDERED CONFIDENTIAL AND PROPRIETARY BY RAIN FOR RENT. ALL DISCLOSURES OF DESIGN INFORMATION AND REPRODUCTION OF THIS DOCUMENT AND ALL SALES RIGHTS ARE EXCLUSIVELY RESERVED BY AND TO RAIN FOR RENT AND COMMUNICATION OF THIS INFORMATION TO OTHERS IS PROHIBITED WITHOUT THE PRIOR WRITTEN CONSENT OF RAIN FOR RENT

SUCTION 6" DISCHARGE 6" MAX. SPHERE 3" IMPELLER 3 VANE

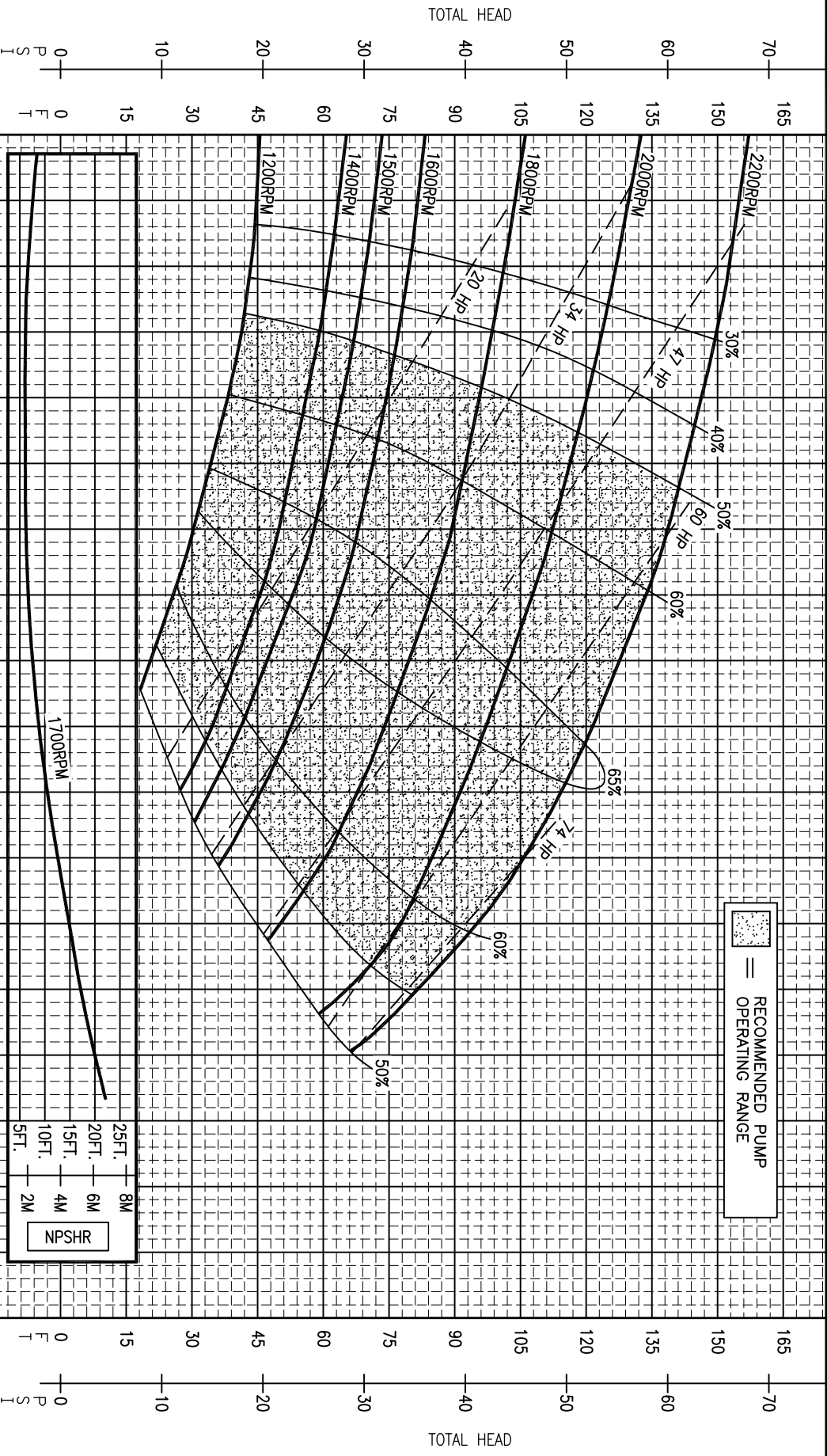

RECOMMENDED PUMP OPERATING RANGE

25FT.	8M
20FT.	6M
15FT.	4M
10FT.	2M
5FT.	2M

NPSHR

FLOW - CLEAR WATER PERFORMANCE (US GPM)
-PUMP PERFORMANCE CURVES DO NOT INCLUDE CHECK VALVE LOSSES
-POWER CURVES INCLUDES AIR COMPRESSOR POWER CONSUMPTION

CONFIDENTIAL