

Sewage and Trash Pump

DV80m

Overview:

The 3" suction x 3" discharge self-priming centrifugal DV80m trash pump provides up to a maximum of 630 gallons per minute pumping and up to 94 feet of head. This pump is usually mounted on a trailer and features the standard PowerPrime Clean Prime Venturi priming system which allows it to run continuously, unattended and even run dry.

Features:

- Continuous self-priming
- Runs dry unattended
- 12 volt, electric start with auto-start capable control panel
- Flex coupled to diesel engine
- 24-hour minimum capacity fuel tank
- Belt driven compressor fitted to operate the air-ejector priming system
- Cast iron wet end with open impellers
- Replaceable wear plates



Specs:

Maximum Flow	630 GPM
Maximum Head	94 feet
Pump Size	3" x 3"
Maximum Solids Handling	1.5 inches
Dry weight	lbs.
Footprint: Trailer mounted model	112.25" x 65"
Fuel tank	40 or 60 gallon
Fuel consumption	0.92 gph @ 2,200 RPM

Accessories:

- Spillguard
- Suction and Discharge Hoses
- Fuel Nurse Tank

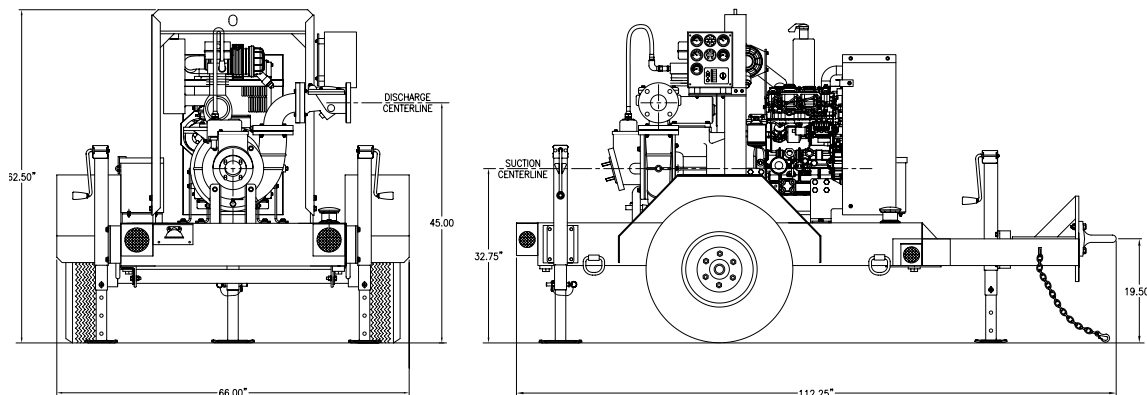

PUMPS • TANKS • FILTRATION • PIPE • SPILLGUARDS

Rain for Rent is a registered trademark of Western Oilfields Supply Company. Features and specifications are subject to change without notice.

Liquid Ingenuity.
800-742-7246
rainforrent.com



Rain For Rent

CURVE: 01-0133-02-04

PUMP : DV-80m

SUCTION
3"

DISCHARGE
3"

MAX. SPHERE
1.5"

IMPELLER
3 VANE

IMPELLER
7.28"

IMPELLER &
WEAR RINGS
316 S/S

ALL INFORMATION CONTAINED IN OR DISCLOSED BY THIS DOCUMENT IS CONSIDERED CONFIDENTIAL AND PROPRIETARY BY RAIN FOR RENT. ALL DISCLOSURES OF DESIGN INFORMATION AND REPRODUCTION OF THIS DOCUMENT AND ALL SALES RIGHTS ARE EXCLUSIVELY RESERVED BY AND TO RAIN FOR RENT AND COMMUNICATION OF THIS INFORMATION TO OTHERS IS PROHIBITED WITHOUT THE PRIOR WRITTEN CONSENT OF RAIN FOR RENT

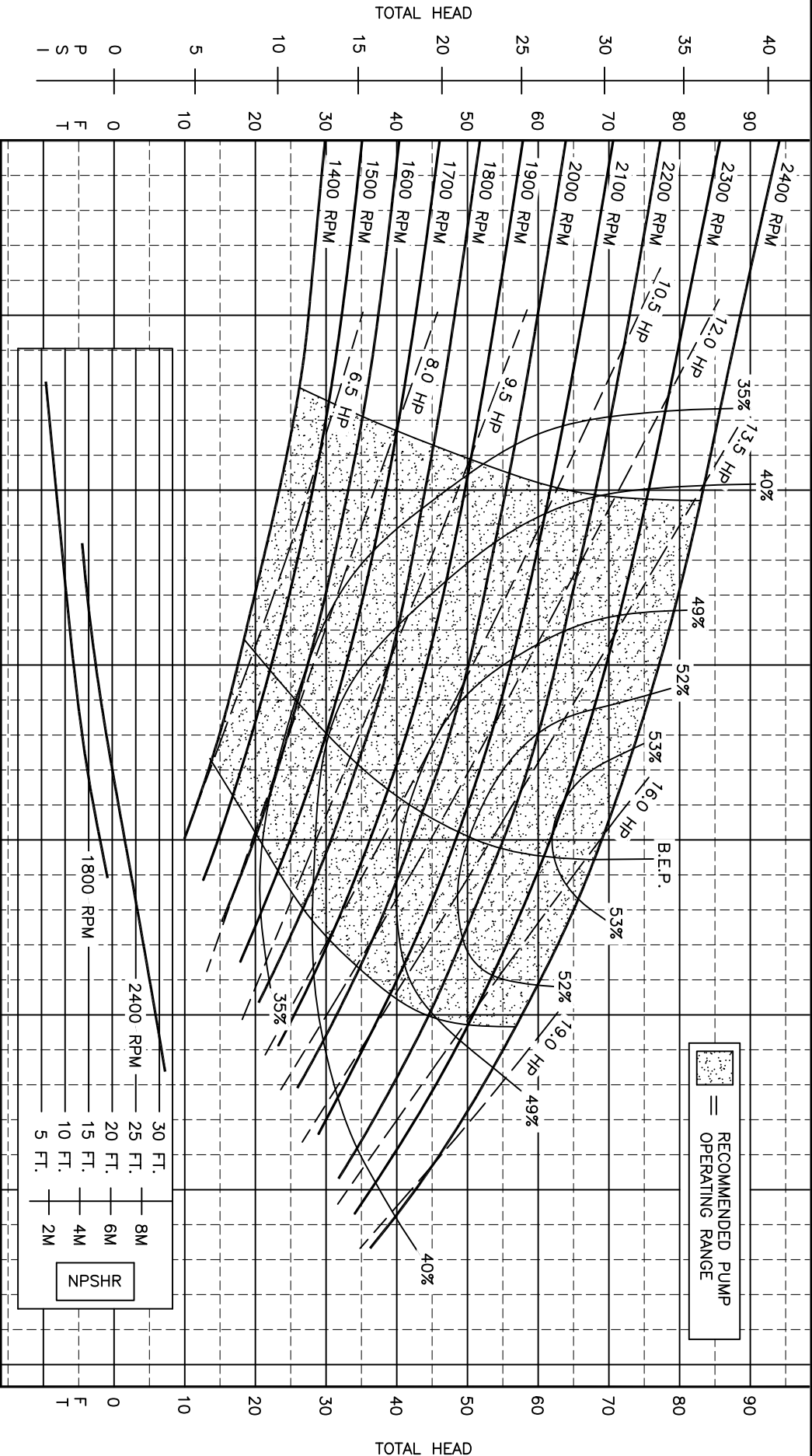

FLOW - CLEAR WATER PERFORMANCE (US GPM)

CONFIDENTIAL

-PUMP PERFORMANCE CURVES DO NOT INCLUDE CHECK VALVE LOSSES
-POWER CURVES INCLUDE AIR COMPRESSOR POWER CONSUMPTION