

High Head Pump

HH225c

Overview:

The 12" suction x 8" discharge self-priming centrifugal HH225c high head pump provides up to a maximum of 5,400 gallons per minute pumping and up to 405 feet of head. This pump is usually mounted on a skid and features the standard PowerPrime Clean Prime Venturi priming system which allows it to run continuously, unattended and even run dry.

Features:

- Suction lift to 28 feet
- Continuous self-priming
- Runs dry unattended
- 12-volt auto start electric control panel
- SAE-mounted
- Flex coupled to diesel engine
- 16-hour capacity fuel tank
- Compressor fitted to operate air-injector priming system
- Caston volute with cast iron 2 vane non-clog impellers
- Replaceable wear rings

Specs:

Maximum Flow	5,400 GPM
Maximum Head	405 feet
Pump Size	12" x 8"
Maximum Solids Handling	3.275 inches
Dry weight	8,950 lbs.
Footprint: Trailer mounted model	176" x 84"
Fuel tank	250 gallon
Fuel consumption	15.4 gph @ 1,900 RPM



Accessories:

- Spillguard
- Suction and Discharge Hoses
- Fuel Nurse Tank
- VFD for electric driven models

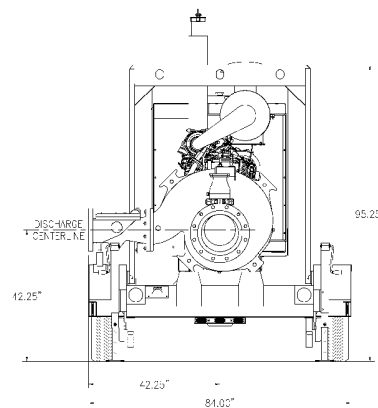
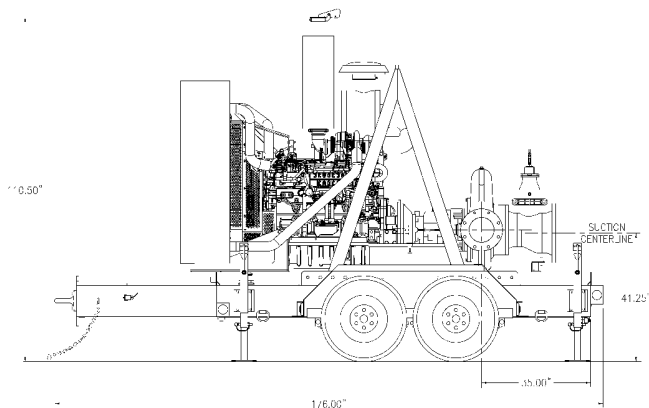

PUMPS • TANKS • FILTRATION • PIPE • SPILLGUARDS

Rain for Rent is a registered trademark of Western Oilfields Supply Company. Features and specifications are subject to change without notice.

Liquid Ingenuity®
800-742-7246
rainforrent.com



Rain For Rent

CURVE: 01-0133-02-25

PUMP : HH-225C

SUCTION
12"

DISCHARGE
8"

MAX. SPHERE
3.38"

IMPELLER
2 VANE

IMPELLER
17.50"

IMPELLER &
WEAR RINGS
CAST IRON

ALL INFORMATION CONTAINED IN OR DISCLOSED BY THIS DOCUMENT IS CONSIDERED CONFIDENTIAL AND PROPRIETARY BY RAIN FOR RENT. ALL DISCLOSURES OF DESIGN INFORMATION AND REPRODUCTION OF THIS DOCUMENT AND ALL SALES RIGHTS ARE EXCLUSIVELY RESERVED BY AND TO RAIN FOR RENT AND COMMUNICATION OF THIS INFORMATION TO OTHERS IS PROHIBITED WITHOUT THE PRIOR WRITTEN CONSENT OF RAIN FOR RENT

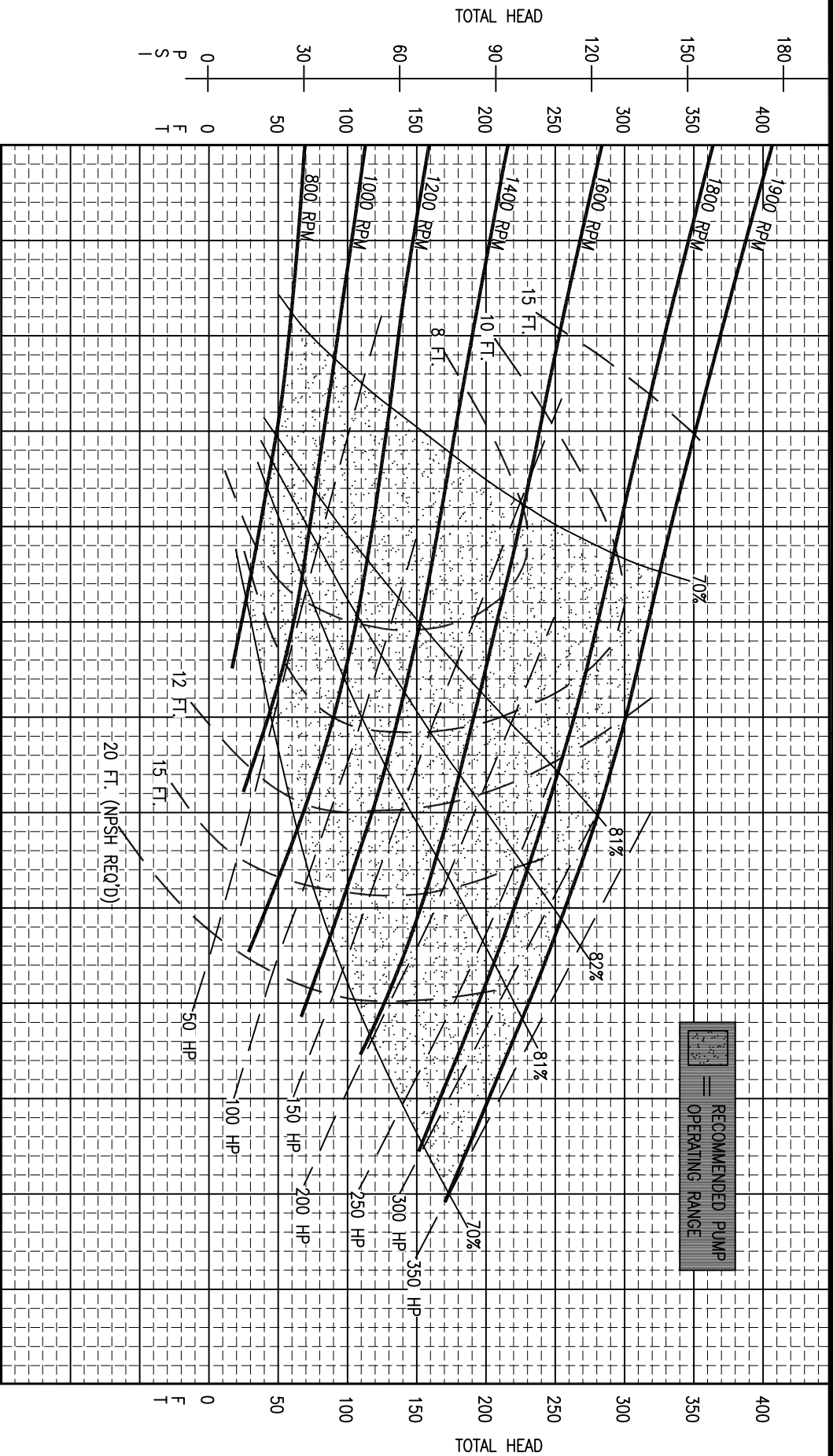

FLOW - CLEAR WATER PERFORMANCE (US GPM)

3000

4000 5000 6000

TOTAL HEAD

CONFIDENTIAL

-PUMP PERFORMANCE CURVES DO NOT INCLUDE CHECK VALVE LOSSES
-POWER CURVES DO NOT INCLUDE PRIMING SYSTEM POWER CONSUMPTION