

# Steel Tank

## 5HP Mixer

### Overview:

Store liquids in confidence with Rain for Rent's 18,100 gallon 5HP Mixer Tank. The tank has three (3) 5HP mixer with three (3) paddles each. The control panel for all mixer motors are explosion proof Class 1 Div. 1. Each mixer has its own on/off/reset switches and breaker. The 5HP Mixer Tanks have a standard "V" shaped floor for ease of draining all stored liquids completely through a 4" butterfly valve with Buna seals standard.

### Features:

- Vapor tight tank rated to 16oz./in<sup>2</sup> of pressure and 0.4 oz./sq.-in. of vacuum
- Three (3) Lightning 5 HP Mixer each with three (3) paddles per shaft
- Explosion proof Class 1 Div. 1 control panels for each 5HP motor
- Explosion proof Class 1 Div. 1 electrical junction box
- OSHA safe stairway with full fall protection handrail system on top of tank.
- Center V-sloped floor for easy draining tank
- One (1) front and rear 4" 150-lb flanges with butterfly valves
- Front connections include one (1) 4" 150lb flange with butterfly valve and one (1) 4" Steel SCH40 threaded connection.
- One (1) 1.5" Steel SCH 80 gauge port
- 2" Steel SCH80 six pass steam coil line with 2" 300lb flange connection.
- Hatch gaskets and valves seats are Buna-N material



### Specs:

Manways	Three (3) 22" hatches
Material	1/4" A36 Steel
Capacity	18,100 gallons
Dry weight	31,000 lbs.
Footprint (LxWxH)	516" x 96" x 120"
Full load amp requirement	Mixers: (3) 5hp motors, 460V, 3-phase, 7.6 full load amps

### Accessories:

- E-CONTAIN® Spillguard
- Suction and Discharge Hoses
- Steam coils
- Level gauges
- PipeStax®
- HoseTrax®

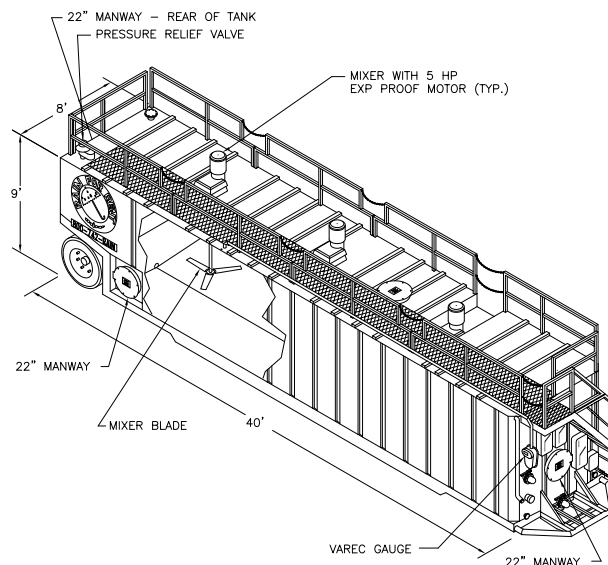

**Liquid Ingenuity.**  
800-742-7246  
rainforrent.com

**PUMPS • TANKS • FILTRATION • PIPE • SPILLGUARDS**

THE SPECIFICATIONS CONTAINED IN THIS SHEET ARE OPERATING GUIDELINES AND ARE INTENDED TO BE GENERAL REPRESENTATIONS OF EQUIPMENT CAPABILITIES. ACTUAL PERFORMANCE WILL VARY BASED UPON SYSTEM APPLICATION, AGE OF EQUIPMENT, MANUFACTURER, AND OPERATION.