

Steel Tank

Bi-Level White

Overview:

Store liquids in confidence with Rain for Rent's 21,000 gallon Steel Bi-level White Tank. These tanks are painted white for temperature control in hot Texas weather. This mobile tank allows your jobsite to have flexibility in planning your project layout. The Bi-level White Tank provides OSHA safe stairways and walkways to make sure your employees are safe when checking water levels or working on the tank. The Bi-level White Tank incorporates a center v-sloped floor to drain the contents of the tank to its lowest level. Rain for Rent also offers internally epoxy coated Bi-level White Tanks to keep your fluids clean for sensitive environmental applications and provide chemical resistance.

Features:

- Vapor Tight Tanks: rated to 16oz/in² of pressure and 0.4oz/in² of vacuum
- V-drain floor with front and rear 4" 150-lb flanges with lever operated butterfly valves
- OSHA Compliant Stairway
- 1.5" Steel SCH80 level gauge port
- 8" External manifold
- Front 3" Steel SCH40 fill line
- Rear top of tank has a 3" 150-lb flanged port
- Front of tank has (1) 4" 150-lb flanges and (1) 4" Steel SCH40 threaded connection
- Hatch gaskets and valve seats are Buna-N material
- Optional: Internal epoxy coating
- Optional: Steam Coils

Specs:

Material	1/4" A36 Steel, Epoxy Coated (Option)
Capacity	21,000-gallons
Manways	Four (4) 22" hatches
Dry weight	26,000-lbs
Footprint:	516" x 96" x 132"



Accessories:

- Radar Level Gauges
- Mechanical Level Gauge
- E-CONTAIN® Spillguard
- SolidGroud® Traction Mats
- PipeStax®
- HoseTrax®
- Suction and Discharge Hose

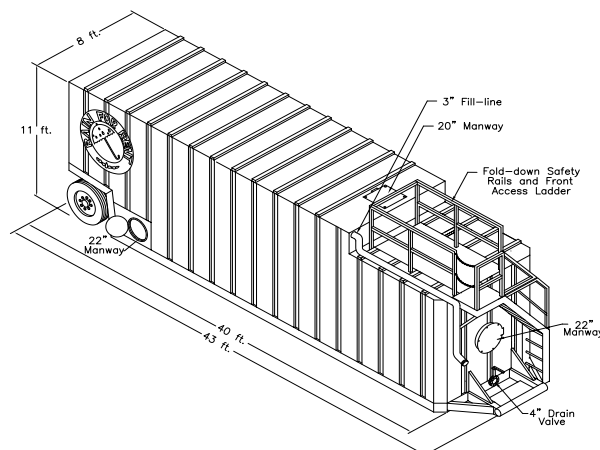

PUMPS • TANKS • FILTRATION • PIPE • SPILLGUARDS

Rain for Rent is a registered trademark of Western Oilfields Supply Company. Features and specifications are subject to change without notice.



Liquid Ingenuity®
800-742-7246
rainforrent.com