

# Electric Trash Pump

DV150IE

## Overview:

The 6" suction x 6" discharge self-priming centrifugal DV150IE electric trash and sewage pump provides up to a maximum of 2,100 gallons per minute pumping and up to 135 feet of head. This pump is usually mounted on a skid and features the standard PowerPrime Clean Prime Venturi priming system which allows it to run continuously, unattended and even run dry.

## Features:

- Continuous self-priming
- Runs dry unattended
- Compressor fitted to operate the air-ejector priming system
- 2 vane, 316 stainless steel, 11.2" impeller
- Suction lift up to 28ft.
- Hot Dip Galvanized Open Skids with fork lift tubes
- Four corner bolt down angles
- Stainless steel and Chrome pump end options
- 50hp 60Hz TEFC hostile duty dual voltage (230/460V)
- Fitted 480 volt control panels are equipped with motor protection
- Panels are equipped with terminal blocks for remote float switches
- Available in Class 1 Division 1 (C1D1) Group C, D configurations

## Specs:

Maximum Flow	2,100 GPM
Maximum Head	135 feet
Pump Size	6" x 6"
Maximum Solids Handling	3 inches
Operating Speed	1,760 rpm
Dry weight	2,250 lbs
Footprint	97" x 49"



## Accessories:

- Spillguard
- Variable Frequency Drive

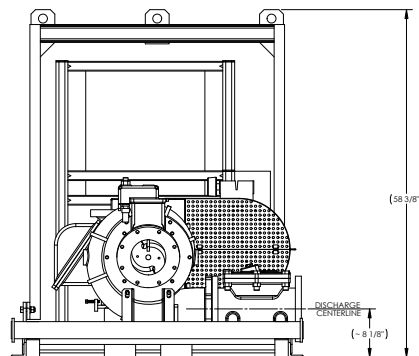
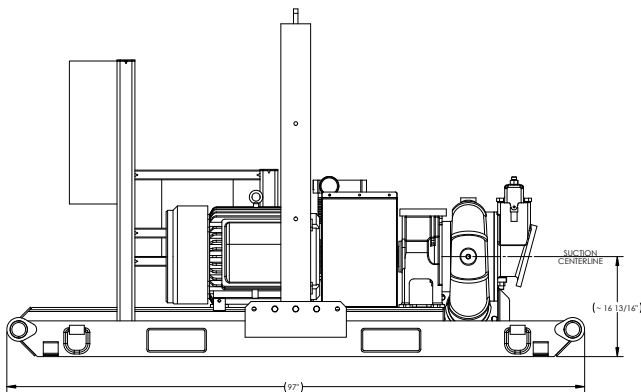

PUMPS • TANKS • FILTRATION • PIPE • SPILLGUARDS

Rain for Rent is a registered trademark of Western Oilfields Supply Company. Features and specifications are subject to change without notice.

**Liquid Ingenuity®**  
800-742-7246  
rainforrent.com

